

LoadHauler 68/90/120:1

These instructions cover the basic gearbox assembly sequence.
For additional information, hints and tips you can refer to our Guidance Section (see brackets).
Note: If this is your first High Level Gearbox we recommend you read all notes thoroughly.

1. While the etches are still in the fret, progressively open out the holes to suit the components, so they're a push-fit (see A & B). Remove all burrs.

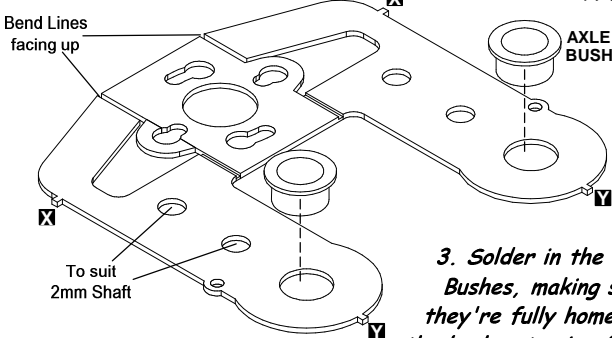

2. Cut the etches from the fret. Take care not to accidentally remove any of the locators 'X' and 'Y'.

3. Solder in the Axle Bushes, making sure they're fully home. File the bushes to size (see C).

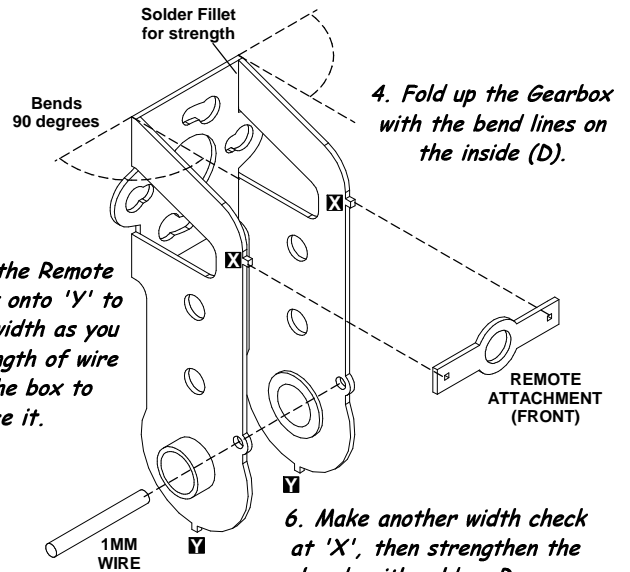

5. Clip on the Remote Attachment onto 'Y' to check the width as you solder a length of wire across the box to brace it.

4. Fold up the Gearbox with the bend lines on the inside (D).

6. Make another width check at 'X', then strengthen the bends with solder. Remove the Attachment and clean up the etches.

7. Stage 1 gears will be one of three types: 15/10T (64:1), 20/10T (90:1) or 27/10 (120:1). They have a single identification dot.

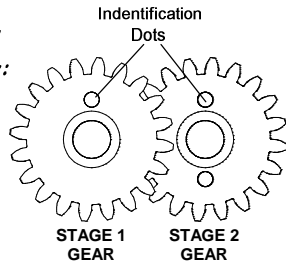

Stage 2 Gears have two dots.

8. Cut the first Gearshaft to length (E) then fit this, along with the Gear and Spacer (F). After checking the gear revolves freely (G) secure the ends of the shaft using a small amount of adhesive. Be careful the glue doesn't stray into the gear itself.

9. Do the same for the Stage 2 Gear. Check the double gears run freely, with some side clearance (G).

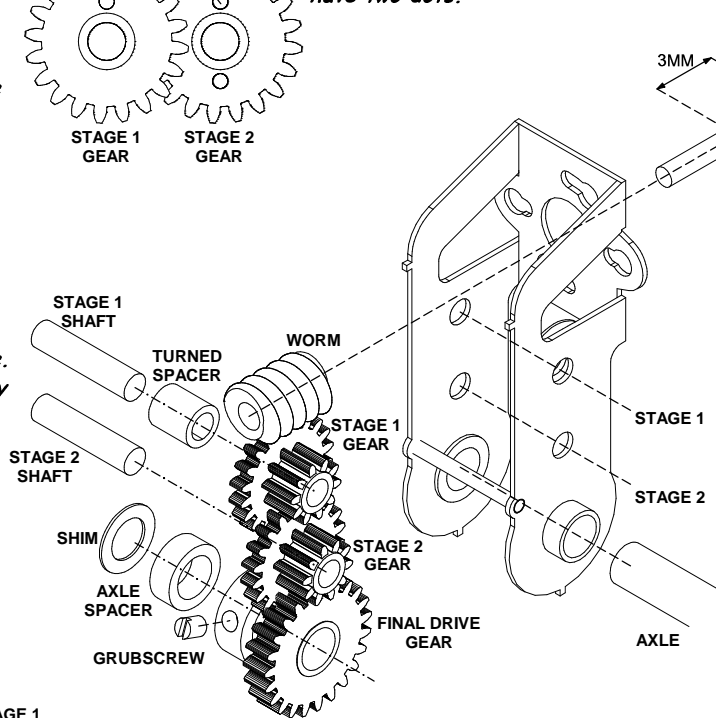
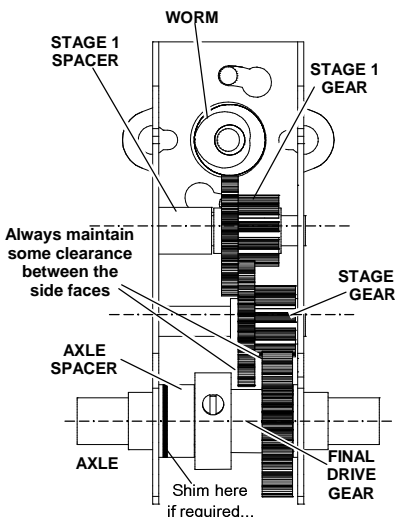

10. Fit the Axle, 23T Gear and Spacer into the box, and Shim if required (read 'J'). Tighten the Grubscrew and check all the gears revolve smoothly.

11. After testing the Motor, push the worm onto the motor shaft (K) so its rear face is 3mm from the Motor face. Secure with Loctite or adhesive.

12. Fit the motor/worm assembly, (L) check the mesh (M) and test the gearbox under power. Lightly lubricate the mechanism (N) then the gearbox is ready to fit (C & J).

The kit includes the additional etched components (P) you will need to convert the gearbox into a remote-drive system, using cardan shafts linked to the motor by universal joints.

