

## 'QuadDriver' 22mm Motor Bogie

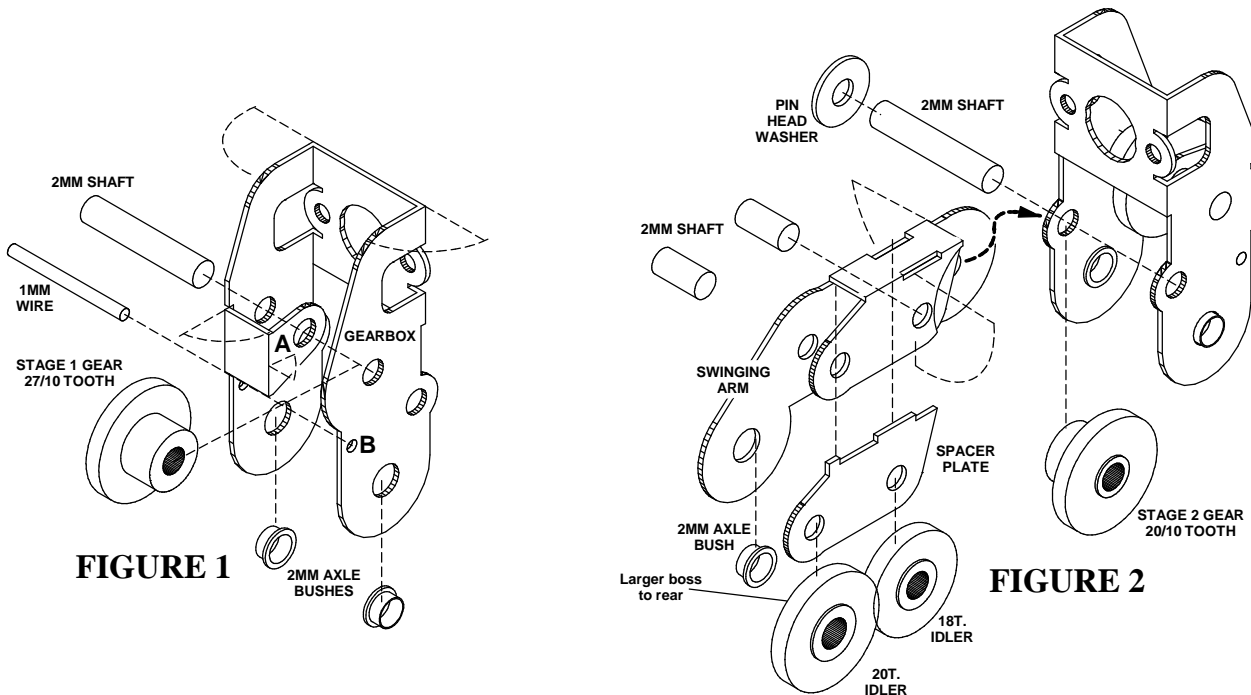

Open out the various holes to the suit the shafts and bushes shown in Figures 1 and 2. Holes should be progressively **reamed out** and the components offered up until they are tight push-fit. Once the unit is assembled, all gearshafts will be fixed with the **gears free to revolve** on them. Remove burrs by inserting the tip of a drill bit (of much larger diameter than the hole) and gently rotating it between your fingers. On both the main Gearbox and Swinging Arm, solder the 2mm **Axle Bushes** into their holes, noting that the shoulders on the bushes are on the **same side** of the etches as the bend lines.

Remove the etches from the fret. **Fold up the etches**, using flat-nosed pliers, gripping near the bend lines to avoid distortion - all bends are 90 degrees - with the bend lines **on the inside** of the gearbox. As you bend the Stage 1 Spacer to shape ('A' in Fig.1) use a length of shaft to line up the holes.

Locate the tabs on the **Spacer Plate** (Fig.2) into the notches in **Swinging Arm** and, using some 2mm shaft to line it up accurately, and solder it in place, hard up against the inside of the swinging arm, as shown. For extra strength, you can strengthen the bends by running a good fillet of solder along them.

To brace the gearbox, solder a length of 1mm wire across, through holes 'B' it, as shown in Figure 1. De-flux all the etches by scrubbing with household cleaner, then rinse and allow to dry. If any of the unit is likely to be visible then **paint it black**.

Use a carborundum disc in a mini-drill to **cut the shafts** - all lengths should be equal to the overall width of the gearbox or swinging arm, with the exception of the Stage 2 shaft, which should be cut to about 12.5mm long. **Wear effective eye protection** - cutting discs can and do disintegrate if they snag. Remove any burrs with a fine file. If the shaft is a tight fit, it will only pass through both sides of the etch if they are truly square. If it won't go through, check to see if the etches have been folded accurately.

During assembly, **check all gears are free from dirt**, grit or other particles. As you build up the geartrain, test for free-running as you add each gear, turning the mechanism with your fingers. If there are any tight spots, do not proceed until they have been eliminated.

Fit the **Stage 1 Gear** (27/10 Tooth double gear) into the main gearbox etch and secure the shaft with a small amount of glue at the end furthest away from the gear.

Push the **Worm** onto the motor shaft until its mid-point is 5mm from the front face of the motor. You may need to open the worm bore out slightly - aim for an easy push-fit, which can be gently forced onto the shaft. Don't use excessive force or the shaft may bend. Instead, use a broach to ease the fit of the worm and then, if necessary, secure the brass worm with a small drop of adhesive at the outer end of the motor shaft.

**Fit the motor** to the gearbox using the fixing screws and sight through the opening in the gearbox sides to check the mesh with the worm - there should be daylight between the gear and the worm, but avoid having too much backlash. If necessary, loosen the motor fixing screws, adjust the mesh. **Test the motor** under power and, when all is well, remove the motor and worm assembly.

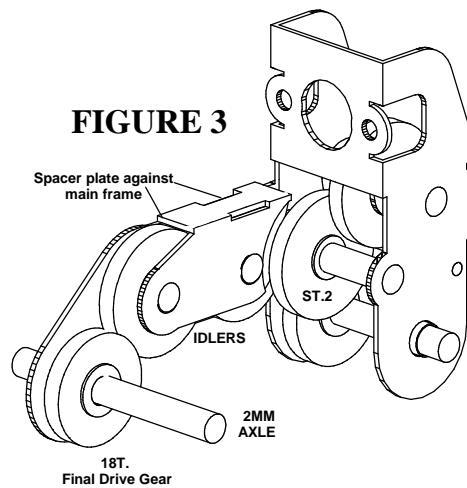

Noting their locations and number of teeth, (they are not interchangeable) fit the two **Idler Gears** (loose-fit on 2mm shaft) into the **Swinging Arm Assembly**, along with their short gearshafts, and secure as above. The larger bosses on the gears should run against the Spacer Plate, as shown in Figures 2 and 3.

Solder the **Pin Head Washer** to the end of the 12.5mm long, Stage 2 gearshaft, flush with one end of the shaft, to make a pin. **Offer up the Swinging Arm Assembly**, complete with gears, to the side face of the gearbox and locate it using the pin, then slide the pin through the gearbox, adding the **Stage 2 gear** (20/10T), as you go. Make sure the pin is pushed fully home, allowing just enough clearance for the arm to swing up and down, but with no perceivable sideways movement, otherwise the idler gears may go **out of mesh**. Secure the free end of the shaft, at the opposite side of the gearbox with glue or solder.

Alternatively, you may benefit from having equal amounts of shaft protruding at either side of the gearbox which will take up less width overall, if you need to site the motor centrally in the chassis – e.g. if the motor fits under a bonnet. To do this, solder the shaft directly into the Swinging Arm and file it flush with the etch. Run the shaft through the gearbox – this time the shaft needs to pivot freely in the holes – and then solder the Pin Head Washer onto the opposite end of the shaft, making sure you don't accidentally solder it to the gearbox.

Re-fit the motor, as above, give 'The Rustler' a final test and then it's ready to be **fitted into your chassis**. The geartrain runs in line with longitudinal axis of the chassis. When the unit is in-situ, it's important that you make arrangements (using washers, spacers etc) in order to prevent the gearbox from moving sideways, or the swinging arm from wandering along the axle. In a compensated chassis, the gearbox should be fitted to the 'fixed' axle, with the Swinging Arm moving vertically on the second axle, which rocks about a central pin.

As you fit the axles, push them through the interference-fit **18T Final Drive Gears**. Position the gears with their larger bosses nearest the axle bushes, so they mesh with the Idler and Stage 2 gear. If these gears are too tight on the axle (axle diameters can vary) then open them out slightly, but be careful.

*Run the completed unit under power, slowly at first, then building up the revs. The gears are effectively self-lubricating, but a little plastics-compatible grease or light oil will do no harm. Do not use general-purpose modelling oil, which attracts dust and grit. Metal-on-metal contact areas (motor bearings, axle bushes) can be lubricated with modelling oil as you would a chassis.*

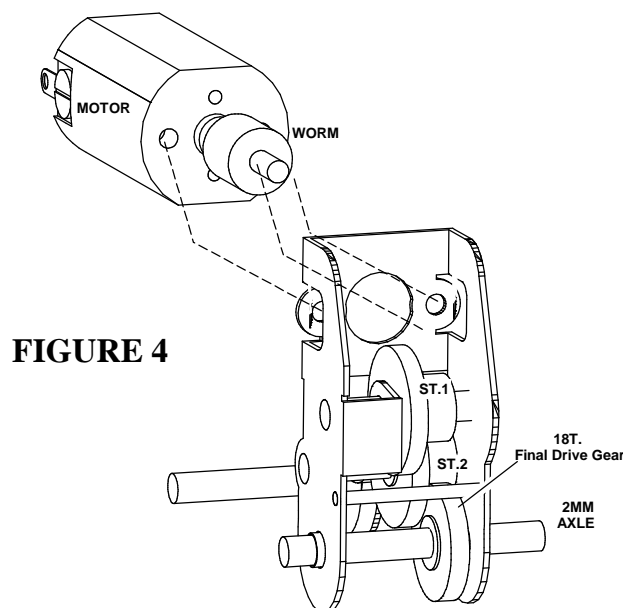

FOR MORE INFORMATION ON HIGH LEVEL *PRECISION* GEARBOXES CONTACT  
HIGH LEVEL, 14 TUDOR ROAD, CHESTER-LE-STREET, CO. DURHAM, DH3 3RY.

WEBSITE - [WWW.HIGHLEVELKITS.CO.UK](http://WWW.HIGHLEVELKITS.CO.UK)

E MAIL - [ENQUIRIES@HIGHLEVELKITS.CO.UK](mailto:ENQUIRIES@HIGHLEVELKITS.CO.UK)